

HM-G Series Horizontal articulated robot

Robot Specifications

(1) HM-G Series Robot Unit (standard type)

Item		Specifications							
Model name of robot set (Note 1)		HM-4060 *G	HM-4A60 *G	HM-4070* G	HM-4A70* G	HM-4085 *G	HM-4A85 *G	HM-40A0 *G	HM-4AA0 *G
Model name of robot unit		HM-4060 *E/GM	HM-4A60 * E/GM	HM-4070* E/GM	HM-4A70* E/GM	HM-4085 *E/GM	HM-4A85 *E/GM	HM-40A0 *E/GM	HM-4AA0 *E/GM
Overall arm length		250(J1: 1st axis) + 350 (J2: 2nd axis) = 600 mm		350(J1: 1st axis) + 350 (J2: 2nd axis) = 700 mm		350(J1: 1st axis) + 500 (J2: 2nd axis) = 850 mm		500(J1: 1st axis) + 500 (J2: 2nd axis) = 1000 mm	
Motion angle and stroke	J1 (1st axis)	±165°							
	J2 (2nd axis)	±143°			±147°				
	Z-axis (3rd axis) vertical stroke*	200 mm if * = 2,		300 mm if * = 3,		400 mm if * = 4			
	Wrist rotation angle T (4th axis)	±360°							
Axis combination		J1 (1st axis) + J2 (2nd axis) + Z (3rd axis) + T (4th axis)							
Maximum payload		10 kg	20 kg	10 kg	20 kg	10 kg	20 kg	10 kg	20 kg
Composite speed	At the center of the hand mounting flange	8,800 mm/s		9,700 mm/s		11,000 mm/s		11,500 mm/s	
	Z	2,760 mm/s				2,300 mm/s		2,110 mm/s	
	T	2220° /s	1540° /s	2220° /s	1540° /s	2220° /s	1540° /s	2220° /s	1540° /s
Position repeatability (Note 2)	J1 + J2	±0.02 mm				±0.025 mm			
	Z	±0.01 mm							
	T	±0.005°							
Maximum force-fit		98N (one second or less)							
Maximum allowable moment of inertia around T axis		0.25 kgm ² (with 10 kg)	0.45 kgm ² (with 20 kg)	0.25 kgm ² (with 10 kg)	0.45 kgm ² (with 20 kg)	0.25 kgm ² (with 10 kg)	0.45 kgm ² (with 20 kg)	0.25 kgm ² (with 10 kg)	0.45 kgm ² (with 20 kg)
Position detection		Absolute encoder							
Drive motor and brake		AC servomotors for all axes Air balanced cylinder for Z axis (3rd axis) Brakes for Z axis (3rd axis) and T axis							
User air piping		4 systems (φ6)							
User signal lines		24 (for proximity sensor signals, etc.)							
Air source	Operating pressure	0.05 to 0.35 MPa							
	Maximum allowable pressure	0.59 MPa							
Weight		Approx. 50 kg (110lbs)							

(Note 1) The model name of robot set refers to the model of a complete set including a robot unit and robot controller.
An asterisk (*) in model names denotes the Z-axis stroke.

(Note 2) Value at the constant ambient temperature.

(2) HM-G-W Series Robot Unit (dust-proof & splash type)

Item		Specifications							
Model name of robot set (Note 1)		HM-4060 *G-W	HM-4A60 *G-W	HM-4070* G-W	HM-4A70* G-W	HM-4085 * G-W	HM-4A85 * G-W	HM-40A0 * G-W	HM-4AA0 * G-W
Model name of robot unit		HM-4060 *E/G M-W	HM-4A60 * E/G M-W	HM-4070* E/GM-W	HM-4A70* E/GM-W	HM-4085 * E/G M-W	HM-4A85 * E/G M-W	HM-40A0 * E/G M-W	HM-4AA0 * E/G M-W
Overall arm length		250(J1: 1st arm) + 350 (J2: 2nd arm) = 600 mm		350(J1: 1st arm) + 350 (J2: 2nd arm) = 700 mm		350(J1: 1st arm) + 500 (J2: 2nd arm) = 850 mm		500(J1: 1st arm) + 500 (J2: 2nd arm) = 1000 mm	
Motion angle and stroke	J1 (1st axis)	±165°							
	J2 (2nd axis)	±140°		±146°		±147°			
	Z-axis (3rd axis) vertical stroke*	200 mm if * = 2,		300 mm if * = 3,		400 mm if * = 4			
	Wrist rotation angle T (4th axis)	±360°							
Axis combination		J1 (1st axis) + J2 (2nd axis) + Z (3rd axis) + T (4th axis)							
Maximum payload		10 kg	20 kg	10 kg	20 kg	10 kg	20 kg	10 kg	20 kg
Composite speed	At the center of the hand mounting flange	7,900 mm/s		8,700 mm/s		9,900 mm/s		10,300 mm/s	
	Z	1,322 mm/s							
	T	2220° /s	1540° /s	2220° /s	1540° /s	2220° /s	1540° /s	2220° /s	1540° /s
Position repeatability (Note 2)	J1 + J2	±0.02 mm				±0.025 mm			
	Z	±0.01 mm							
	T	±0.005°							
Maximum force-fit		98N (one second or less)							
Maximum allowable moment of inertia around T axis		0.25 kgm ² (with 10 kg)	0.45 kgm ² (with 20 kg)	0.25 kgm ² (with 10 kg)	0.45 kgm ² (with 20 kg)	0.25 kgm ² (with 10 kg)	0.45 kgm ² (with 20 kg)	0.25 kgm ² (with 10 kg)	0.45 kgm ² (with 20 kg)
Position detection		Absolute encoder							
Drive motor and brake		AC servomotors for all axes Brakes for Z axis (3rd axis) and T axis							
User air piping		4 systems (φ6)							
User signal lines		24 (for proximity sensor signals, etc.)							
Air source	Operating pressure	0.05 to 0.35 MPa							
	Maximum allowable pressure	0.59 MPa							
Degree of protection		IP65							
Weight		Approx. 50 kg (110lbs)							

(Note 1) The model name of robot set refers to the model of a complete set including a robot unit and robot controller.
An asterisk (*) in model names denotes the Z-axis stroke.

(Note 2) Value at the constant ambient temperature.

(3) HMS-G Series Robot Unit (overhead-mount, standard type)

Item		Specifications			
Model name of robot set (Note 1)		HMS-4070*G	HMS-4A70*G	HMS-4085*G	HMS-4A85*G
Model name of robot unit		HMS-4070* E/GM	HMS-4A70* E/GM	HMS-4085* E/GM	HMS-4A85* E/GM
Overall arm length		350(J1: 1st axis) + 350 (J2: 2nd axis) = 700 mm		350(J1: 1st axis) + 500 (J2: 2nd axis) = 850 mm	
Motion angle and stroke	J1 (1st axis)	±165°			
	J2 (2nd axis)	±145°		±142°	
	Z-axis (3rd axis) vertical stroke*	200 mm if * = 2, 300 mm if * = 3, 400 mm if * = 4			
	Wrist rotation angle T (4th axis)	±360°			
Axis combination		J1 (1st axis) + J2 (2nd axis) + Z (3rd axis) + T (4th axis)			
Maximum payload		10 kg	20 kg	10 kg	20 kg
Composite speed	At the center of the hand mounting flange	9,700 mm/s		11,000 mm/s	
	Z	2,760 mm/s		2,300 mm/s	2,110 mm/s
	T	2220° /s	1540° /s	2220° /s	1540° /s
Position repeatability (Note 2)	J1 + J2	±0.02 mm		±0.025 mm	
	Z	±0.01 mm			
	T	±0.005°			
Maximum force-fit		98N (one second or less)			
Maximum allowable moment of inertia around T axis		0.25 kgm ² (with 10 kg)	0.45 kgm ² (with 20 kg)	0.25 kgm ² (with 10 kg)	0.45 kgm ² (with 20 kg)
Position detection		Absolute encoder			
Drive motor and brake		AC servomotors for all axes Air balanced cylinder for Z axis (3rd axis) Brakes for Z axis (3rd axis) and T axis			
User air piping		4 systems (φ6)			
User signal lines		24 (for proximity sensor signals, etc.)			
Air source	Operating pressure	0.05 to 0.35 MPa			
	Maximum allowable pressure	0.59 MPa			
Weight		Approx. 50 kg (110lbs)			

(Note 1) The model name of robot set refers to the model of a complete set including a robot unit and robot controller.
An asterisk (*) in model names denotes the Z-axis stroke.

(Note 2) Value at the constant ambient temperature.

(4) HMS-G-W Series Robot Unit (overhead-mount, dust-proof & splash type)

Item		Specifications			
Model name of robot set (Note 1)		HMS-4070*G-W	HMS-4A70*G-W	HMS-4085*G-W	HMS-4A85*G-W
Model name of robot unit		HMS-4070*E/GM-W	HMS-4A70*E/GM-W	HMS-4085*E/GM-W	HMS-4A85*E/GM-W
Overall arm length		350(J1: 1st arm) + 350 (J2: 2nd arm) = 700 mm		350(J1: 1st arm) + 500 (J2: 2nd arm) = 850 mm	
Motion angle and stroke	J1 (1st axis)	±165°			
	J2 (2nd axis)	±142°			
	Z-axis (3rd axis) vertical stroke*	200 mm if * = 2, 300 mm if * = 3, 400 mm if * = 4			
	Wrist rotation angle T (4th axis)	±360°			
Axis combination		J1 (1st axis) + J2 (2nd axis) + Z (3rd axis) + T (4th axis)			
Maximum payload		10 kg	20 kg	10 kg	20 kg
Composite speed	At the center of the hand mounting flange	8,700 mm/s		9,900 mm/s	
	Z	1,322 mm/s			
	T	2220° /s	1540° /s	2220° /s	1540° /s
Position repeatability (Note 2)	J1 + J2	±0.02 mm		±0.025 mm	
	Z	±0.01 mm			
	T	±0.005°			
Maximum force-fit		98N (one second or less)			
Maximum allowable moment of inertia around T axis		0.25 kgm ² (with 10 kg)	0.45 kgm ² (with 20 kg)	0.25 kgm ² (with 10 kg)	0.45 kgm ² (with 20 kg)
Position detection		Absolute encoder			
Drive motor and brake		AC servomotors for all axes Brakes for Z axis (3rd axis) and T axis			
User air piping		4 systems (φ6)			
User signal lines		24 (for proximity sensor signals, etc.)			
Air source	Operating pressure	0.05 to 0.35 MPa			
	Maximum allowable pressure	0.59 MPa			
Degree of protection		IP65			
Weight		Approx. 50 kg (110lbs)			

(Note 1) The model name of robot set refers to the model of a complete set including a robot unit and robot controller.
An asterisk (*) in model names denotes the Z-axis stroke.

(Note 2) Value at the constant ambient temperature

HM-G Series Horizontal articulated robot

Outer Dimensions and Workable Space

(1) HM-G Series (floor-mount, standard type)

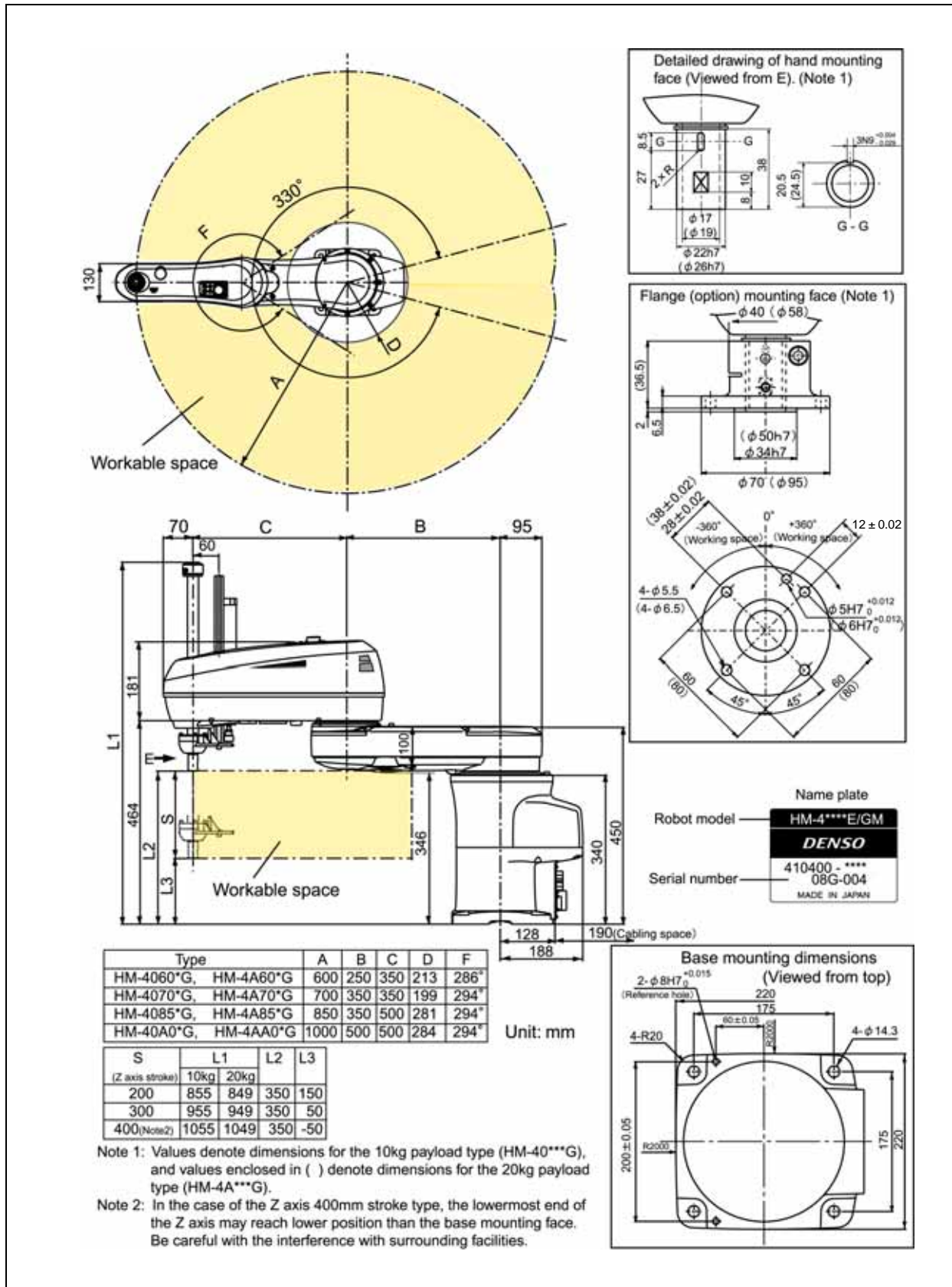

(2) HM-G-W Series (floor-mount, dust-proof & splash type)

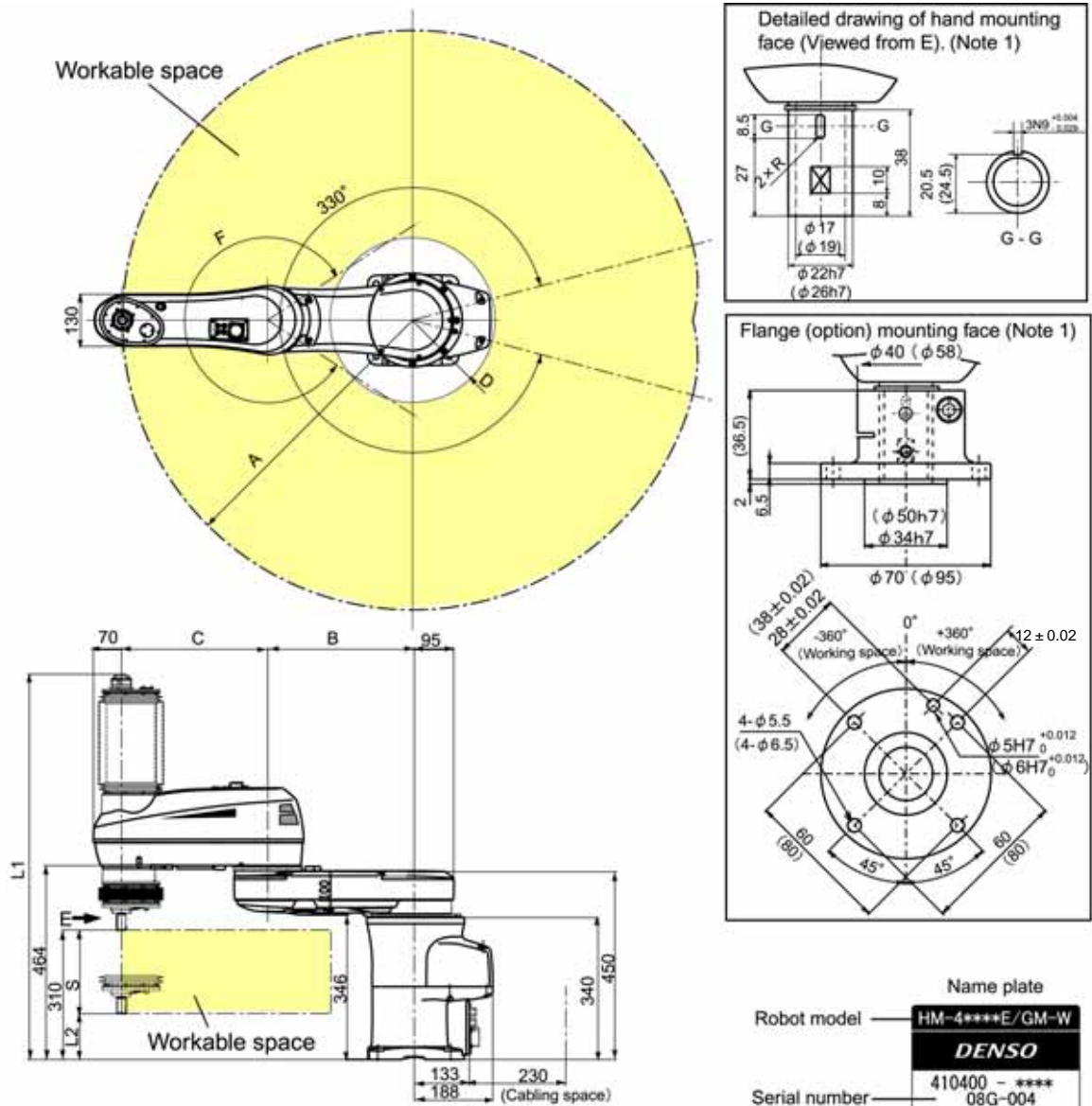

Type	A	B	C	D	F
HM-4060*G-W, HM-4A60*G-W	600	250	350	226	280°
HM-4070*G-W, HM-4A70*G-W	700	350	350	205	292°
HM-4085*G-W, HM-4A85*G-W	850	350	500	281	294°
HM-40A0*G-W, HM-4AA0*G-W	1000	500	500	284	294°

S (Z axis stroke)	L1	L2
200	925	110
300	1025	10
400 (Note2)	1125	-90

Note 1: Values denote dimensions for the 10kg payload type (HM-40***G-W), and values enclosed in () denote dimensions for the 20kg payload type (HM-4A***G-W).

Note 2: In the case of the Z axis 400mm stroke type, the lowermost end of the Z axis may reach lower position than the base mounting face. Be careful with the interference with surrounding facilities.

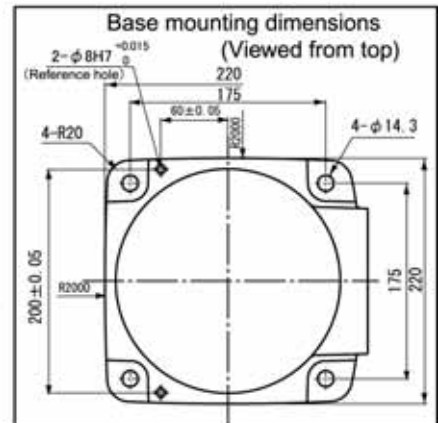

(3) HMS-G Series (overhead-mount, standard type)

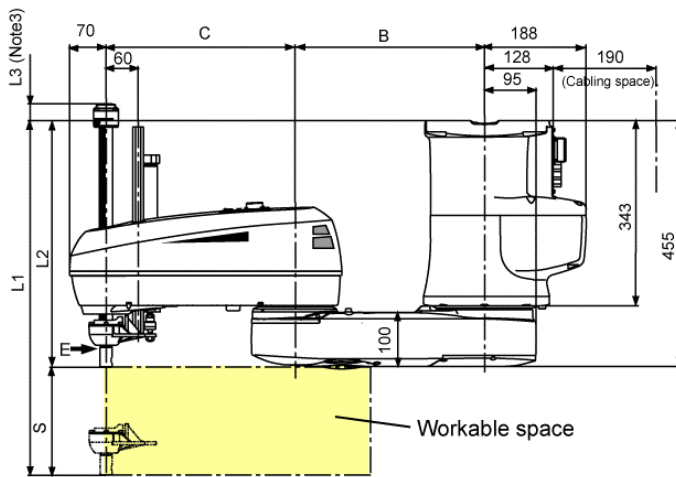
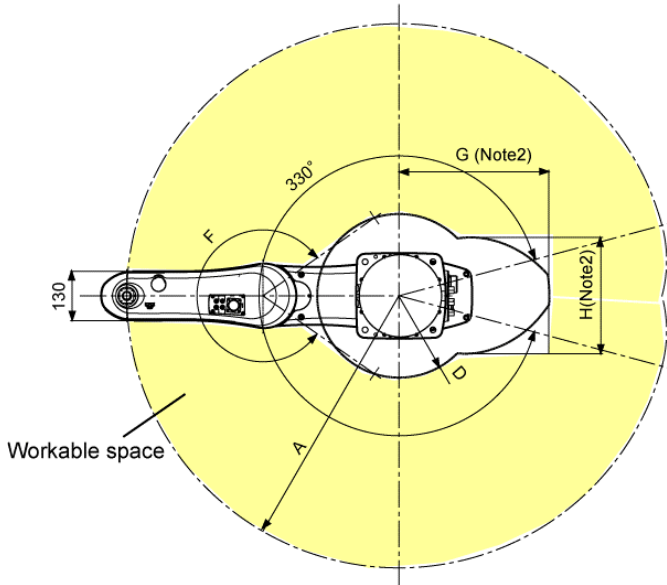

Unit: mm

Type	A	B	C	D	F	G	H
HMS-4070*G, HMS-4A70*G	700	350	350	211	290	387	300
HMS-4085*G, HMS-4A85*G	850	350	500	311	284	397	178

S (Z axis stroke)	L1	L2	L3	
			10kg	20kg
200	-656	-456	49	43
300	-756	-456	149	143
400	-856	-456	249	243

Note 1: Values denote dimensions for the 10kg payload type (HMS-40***G), and values enclosed in () denote dimensions for the 20kg payload type (HMS-4A***G).

Note 2: The workable space is limited so that the unit does not interfere with the cables.

Note 3: In the case of the overhead-mount type, the uppermost end of the Z axis may reach higher position than the base mounting face. Be careful with the interference with surrounding facilities.

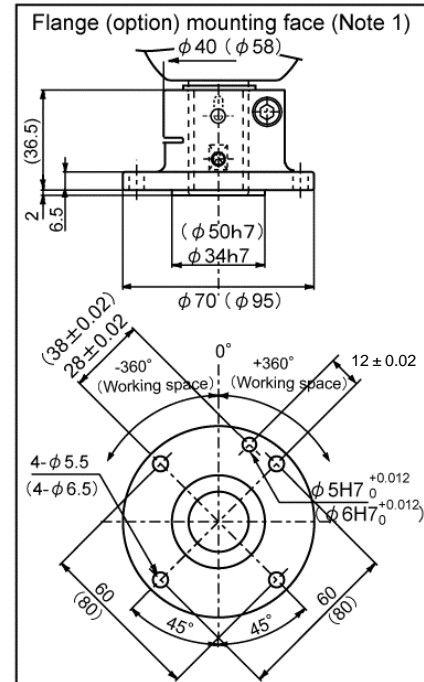
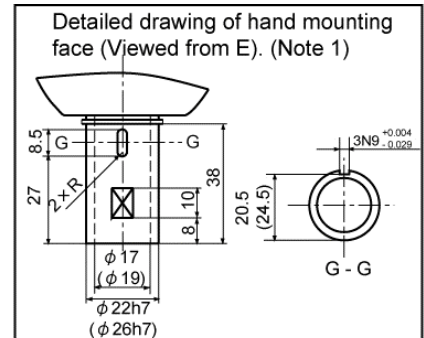

Name plate

Robot model	HMS-4***E/GM
DENSO	
Serial number	410400 - **** 08G-004
MADE IN JAPAN	

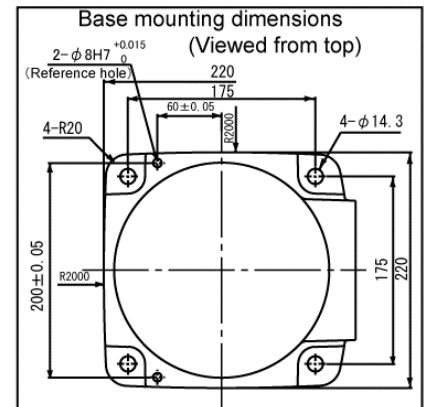

(4) HMS-G-W Series (overhead-mount, dust-proof & splash type)

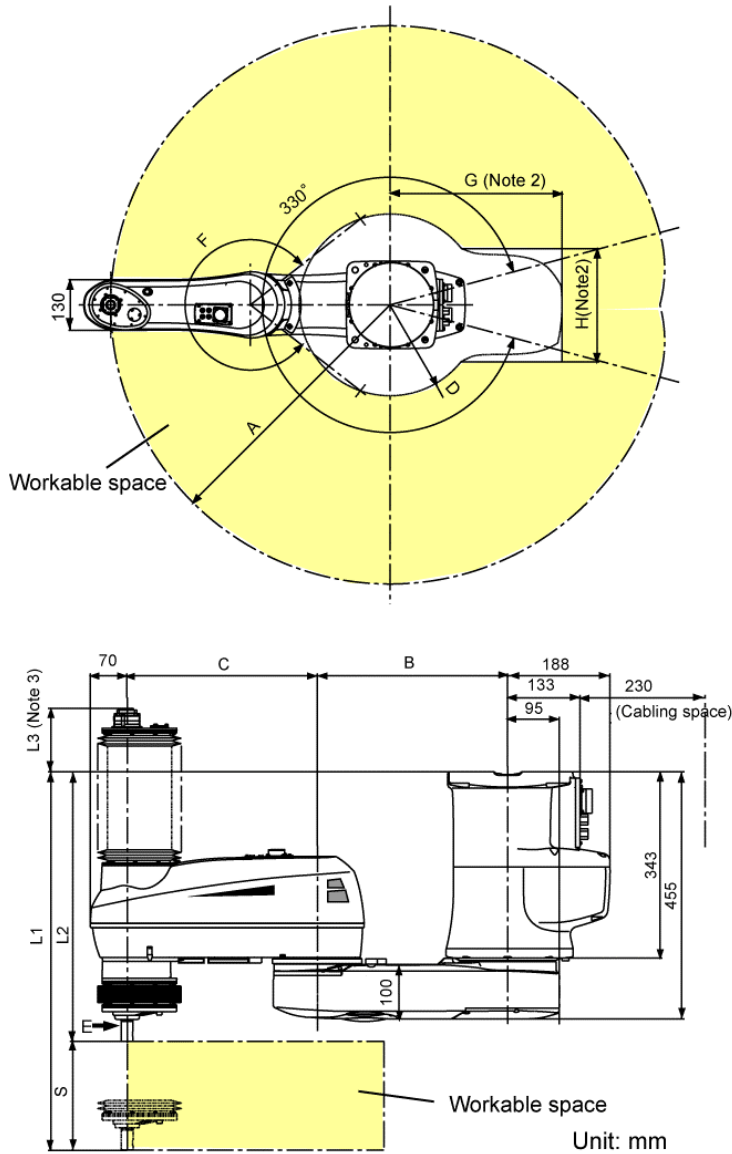

Type	A	B	C	D	F	G	H
HMS-4070*G-W, HMS-4A70*G-W	700	350	350	228	284°	431	284
HMS-4085*G-W, HMS-4A85*G-W	850	350	500	311	284°	439	237

S (Z axis stroke)	L1	L2	L3
200	-696	-496	119
300	-796	-496	219
400	-896	-496	319

Note 1: Values denote dimensions for the 10kg payload type (HMS-40***G-W), and values enclosed in () denote dimensions for the 20kg payload type (HMS-4A***G-W).

Note 2: The workable space is limited so that the unit does not interfere with the cables.

Note 3: In the case of the overhead-mount type, the uppermost end of the Z axis may reach higher position than the base mounting face. Be careful with the interference with surrounding facilities.

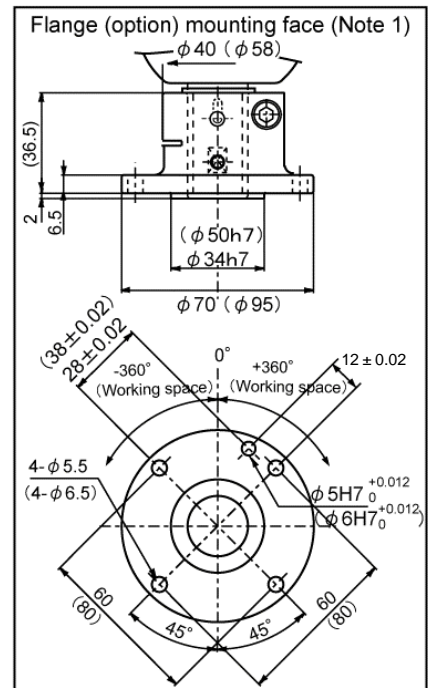
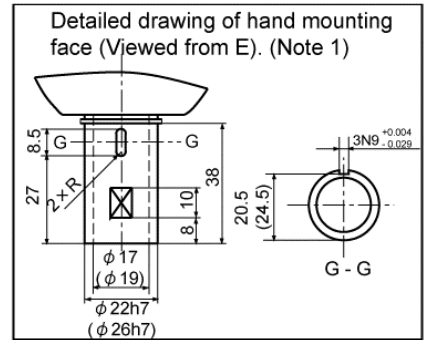

Name plate

Robot model — HMS-4****E/GM-W

DENSO

Serial number — 410400 - ****
08G-004

MADE IN JAPAN

